



## Standard Features

- Full Proportional Control
- **vSAFE-BASE** Electronic Stability and Limitation System
- Cable Remote Control
- Remote Control Socket on Chassis and Basket
- Acoustic and Visual Warning System
- 1.4 x 0.7 x 1.10 m Aluminum Basket
- 380° Turret Rotation
- ± 85° Basket Rotation
- Automatic Hydraulic Basket Levelling System
- Emergency Hand Pump
- Ergonomic Operator Cabin
- Engine Start/Stop ve RPM System\*
- Toolbox on Chassis
- Basket Working Lights

## Optional Features

- Multi-Language Color Display for Information and Diagnosis
- Cabin-Basket Intercom
- 220V 16A Power Outlet in Basket
- Operator Cabin Heating-Cooling
- 3-Phase AC Motor Pump for Green Usage
- Basket Wind Sensor-Anemometer
- Custom Paintwork
- Isolated Basket
- Rubber Stabilizer Pads
- Extra Working Lights
- Remote Assistance and Cloud System(IoT)

\* Depends on truck type

## Technical Data

- Maximum Working Height 30m
- Maximum Lateral Outreach 20m (100kg)
- Basket Load Capacity  250kg
- Turret Rotation  $\pm 180^\circ$
- Basket Size 1.4x0.7x1.10m
- Basket Rotation  $\pm 85^\circ$
- Total Weight\* 8.5T
- Transport Length (A)\* 8.55m
- Transport Height (B)\* 3.2m
- Transport Width (C)\* 2.25m

\* Depends on truck type

## Working Diagram

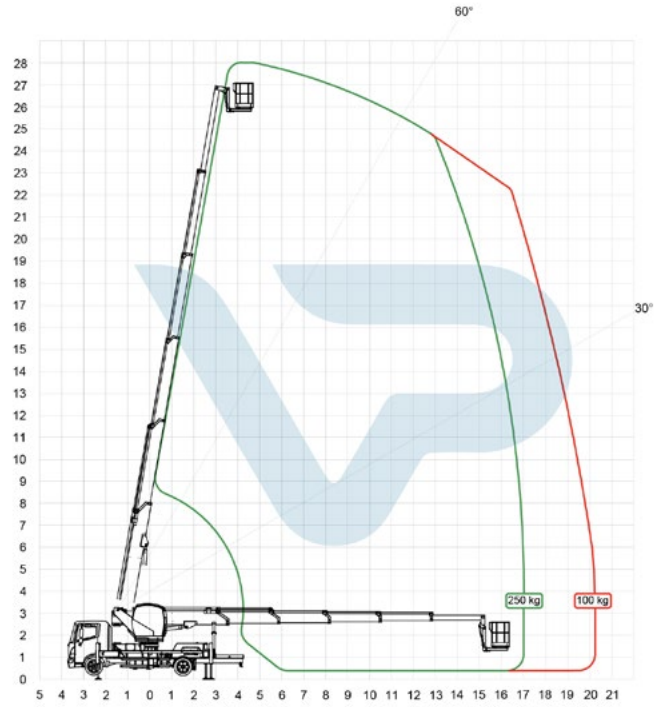

## Technical Drawings

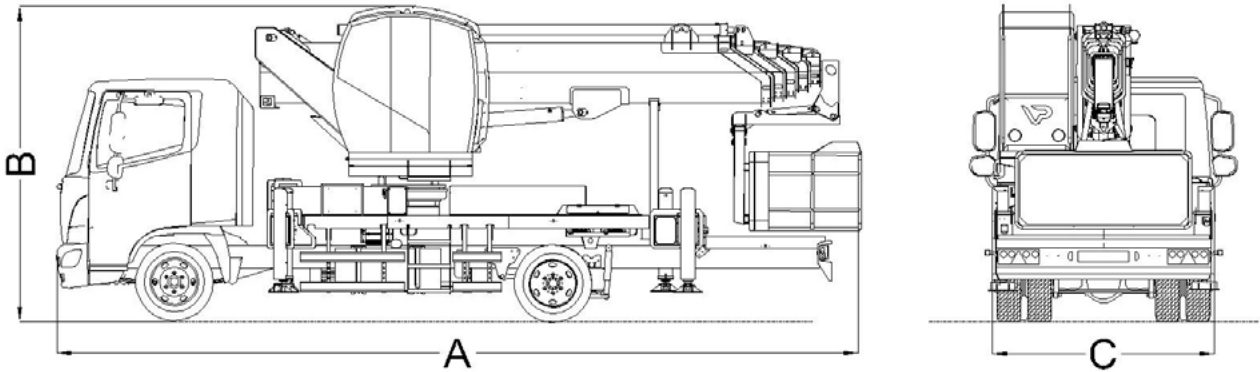

### IMPORTANT

Due to continuous product improvements, VESA PLATFORM reserves the right to make specification and/or equipment changes without prior notification.

 VESA PLATFORM

San. Tic. Ltd. Şti

Fevziçakmak Mah. Milenyum Cad. No:73/1  
Karatay/KONYA TURKEY

0850 420 8372(VESA)  
info@vesaplatform.com  
www.vesaplatform.com

